

Westlakes Print, Boolaroo — 58-1333

**Model No. HE-NC6**

**(6 STAGE)**

**ELECTRIC KILN  
CONTROLLER**

**OPERATORS  
MANUAL**

MANUFACTURED BY

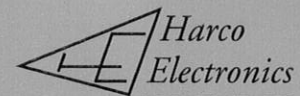

97 Jubilee Rd  
Elernore Vale  
N.S.W. 2287  
AUSTRALIA



27A Yeo Street, Victoria Point QLD 4165  
PO BOX 5220, Victoria Point QLD 4165  
Office Tel: 07 3820 7037  
Mobile: 0427 105 456  
thermaltechnologies.com.au  
sales@thermaltechnologies.com.au  
ABN: 11 358 865 293

## Dear Customer Purchaser,

The following booklet is set out specifically to assist you in becoming familiar with your new controller.

If you follow the steps and examples you should have little difficulty in understanding the unit.

However should a problem arise do not hesitate in contacting your local agent for assistance.

The unit has been carefully designed for ease of use and maximum reliability and should give you years of trouble free running.

Although each unit is carefully assembled and factory tested it is possible that a defective component may slip through, therefore in the event of a fault occurring you are protected during the initial period by the warranty set out in the booklet.

As an Australian manufacturer I personally feel that a good reputation is only acquired by producing quality products, which leads to satisfied customers.

**Manager,  
HARCO ELECTRONICS**

### **WARNING**

Please READ CAREFULLY the information in the manual prior to USING the controller so that you UNDERSTAND how to SET the unit CORRECTLY.

Failure to do so may result in DAMAGE to the KILN or it's CONTENTS.

**THE CONTROLLER SHOULD NOT BE LEFT UNATTENDED.  
DO SO AT YOUR OWN RISK.**

# OPERATING INSTRUCTIONS FOR 6 STAGE ELECTRIC CONTROLLER

## SELECTING THE REQUIRED PROGRAM

There are 8 user settable PROGRAMS in the controller, which remain set even when the power is OFF.

Each PROGRAM contains 6 STAGES. (these are detailed below).

- Denotes ON or Blinking
- Denotes OFF

Turn ON the power, then push and release **RESET**.

### NOTE

During this section you may check the kiln temperature at any time by pushing and holding **TEMP**.

The PROGRAM NUMBER that was LAST SET **001** to **008** will be displayed.

To CHANGE the program number push **UP** or **DOWN**.

Push **ENTER** when the desired PROGRAM is selected.

The Harco number will appear in the display.

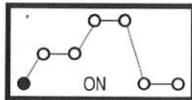

## SELECTING A HARCO NUMBER

IF YOU DO NOT REQUIRE A NUMBER SET TO **000**.

Push **UP** or **DOWN** to select the number required.  
(refer to HARCO NUMBER TABLES)

Push **ENTER** to go to stage 1.

## SETTING UP THE SELECTED PROGRAM (Stages 1 to 6)

### STAGE 1. UP STAGE ONLY

Push and hold **TEMP** to read and select the TEMPERATURE setting.

On release of **TEMP** you may now change the setting by pushing **UP** or **DOWN**.

Enter the TEMPERATURE setting by pushing **ENTER** until the kiln temperature appears.

Push and hold **RATE/TIME** to read and select the RATE setting.

On release of **RATE/TIME** you may now set the RATE (degrees per hour) by pushing **UP** or **DOWN**.

Enter the RATE setting by pushing **ENTER** until the kiln temperature appears.

Push **CYCLE** to go to stage 2.

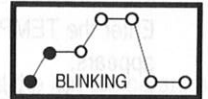

### STAGE 2. SOAK/HOLD or UP STAGE ONLY

IF YOU HAVE JUST SET STAGE 1 TEMPERATURE THE SETTING OF STAGE 2 WILL HAVE BEEN SET TO THE SAME READING AS STAGE 1. THE TEMPERATURE SETTING MUST BE THE SAME AS STAGE 1 IF YOU WANT A SOAK/HOLD STAGE.

Push and hold **TEMP** to read the TEMPERATURE setting.

On release of **TEMP** you may now set the TEMPERATURE by pushing **UP** or **DOWN**.

(TEMPERATURE MUST BE THE SAME OR GREATER THAN STAGE 1.)

Enter the TEMPERATURE setting by pushing **ENTER** until the kiln temperature appears.

Push and hold **RATE/TIME** to read the RATE or TIME setting.

If you have set the temperature of this stage GREATER than STAGE 1 you are setting an UP STAGE = RATE. (degrees per hour).

If you have set the temperature of this stage the SAME as STAGE 1 you are setting a SOAK/HOLD STAGE = TIME. (minutes).

On release of **RATE/TIME** you may now set the RATE (UP STAGE) or TIME (SOAK/HOLD STAGE) by pushing **UP** or **DOWN**.

Enter the RATE or TIME setting by pushing **ENTER** until the kiln temperature appears.

Push **CYCLE** to go to STAGE 3.

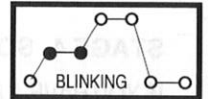

### STAGE 3. UP STAGE ONLY

Push and hold **TEMP** to select or read the TEMPERATURE setting.

On release of **TEMP** you may now change the setting by pushing **UP** or **DOWN**. (MUST BE GREATER THAN STAGE 2).

Enter the TEMPERATURE setting by pushing **ENTER** until the kiln temperature appears.

Push and hold **RATE/TIME** to select or read the RATE setting.

On release of **RATE/TIME** you may now set the RATE (degrees per hour) by pushing **UP** or **DOWN**.

Enter the RATE setting by pushing **ENTER** until the kiln temperature appears.

Push **CYCLE** to go to STAGE 4.

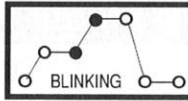

### STAGE 4. SOAK/HOLD or UP STAGE ONLY

IF YOU HAVE JUST SET STAGE 3 THE TEMPERATURE SETTING OF THIS STAGE WILL HAVE BEEN SET TO THE SAME READING AS STAGE 3. THE TEMPERATURE SETTING MUST BE THE SAME AS STAGE 3 IF YOU WANT A SOAK/HOLD STAGE.

Push and hold **TEMP** to read the TEMPERATURE setting.

On release of **TEMP** you may now set the TEMPERATURE by pushing **UP** or **DOWN**.

( MUST BE THE SAME OR GREATER THAN STAGE 3.)

Enter the TEMPERATURE setting by pushing **ENTER** until the kiln temperature appears.

Push and hold **RATE/TIME** to select or read the RATE or TIME setting.

If you have set the temperature of this stage GREATER than stage 3 you are setting an UP STAGE = RATE. (degrees per hour).

If you have set the temperature of this STAGE the SAME as stage 3 you are setting a SOAK/HOLD stage = TIME. (minutes).

On release of **RATE/TIME** you may now set the RATE or TIME by pushing **UP** or **DOWN**.

Enter the RATE or TIME setting by pushing **ENTER** until the kiln temperature appears.

Push **CYCLE** to go to STAGE 5.

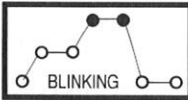

### STAGE 5. DOWN STAGE ONLY

Push and hold **TEMP** to select or read the TEMPERATURE setting.

On release of **TEMP** you may now change the setting by pushing **UP** or **DOWN**. (must be LESS than STAGE 4).

Enter the TEMPERATURE setting by pushing **ENTER** until the kiln temperature appears.

Push and hold **RATE/TIME** to select or read the RATE setting.

On release of **RATE/TIME** you may now set the RATE (degrees per hour) by pushing **UP** or **DOWN**.

Enter the RATE setting by pushing **ENTER** until the kiln temperature appears.

Push **CYCLE** to go to STAGE 6.

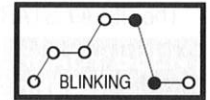

### STAGE 6. SOAK STAGE ONLY

Push and hold **TEMP** to read the TEMPERATURE setting. YOU CANNOT ALTER TEMPERATURE SETTING OF THIS STAGE. (It is set by Stage 5).

Push and hold **RATE/TIME** to read the TIME setting.

On release of **RATE/TIME** you may now set the TIME (minutes) by pushing **UP** or **DOWN**.

Enter the TIME setting by pushing **ENTER** until the kiln temperature appears.

Push **CYCLE** to go to delay start time.

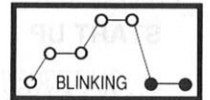



The DELAY START TIME allows the user to set a time that must elapse before the controller will start.

#### EXAMPLE

If it is now 7.00pm and you want the controller to start at 9.00pm, set the DELAY START TIME to the difference between the two times.

120 Minute Model.

002 Hour Model.

#### DELAY START TIME



Push and hold **[RATE/TIME]** to read TIME.

Will read **[000]** before being set.

On release of **[RATE/TIME]** you may now set the DELAY START TIME by pushing **[UP]** or **[DOWN]**. (leave at **[000]** if not required.)

WHEN YOU HAVE SET THE TIME YOU REQUIRE YOU MAY GO ON.

Push and release **[CYCLE]** to start.

#### START UP

The DELAY START TIME will appear in the display.

The CONTROL light will be OFF.

The DELAY TIMER light will be on.

The controller will start the cycle when the TIME = **[000]**.

#### ALARM STATE

When the controller goes into an ALARM STATE.

- The alarm light will blink.
- An audible BEEPER will sound.
- The CONTROL POWER from the controller will be OFF.

#### IMPORTANT

THE ALARM STATE SIGNIFIES THAT SOMETHING IS WRONG WITH THE SYSTEM, **NOT SOMETHING WRONG WITH THE CONTROLLER.**

#### AUTOSTART

**IF THE PROGRAM YOU HAVE SELECTED HAS ALREADY BEEN SET UP, YOU MAY USE THE AUTOSTART PROCEDURE.**

- PUSH and release **[RESET]**.
- Push **[UP]** or **[DOWN]** to select the desired program number **[001]** to **[008]**.
- Push and HOLD **[ENTER]** until the HARCO NUMBER appears and the BEEPER SOUNDS.

The controller will now AUTOMATICALLY run through the start up sequence and start.

#### IMPORTANT

THE SETTINGS WILL BE DISPLAYED WITH A BEEP TO ALLOW YOU TO CHECK THAT YOUR SETTINGS ARE CORRECT AS FOLLOWS.

#### CHANGE TO STAGE 1

BEEP TEMPERATURE SETTING BEEP RATE SETTING

#### CHANGE TO STAGE 2

BEEP TEMPERATURE SETTING BEEP RATE/TIME SETTING

#### CHANGE TO STAGE 3

BEEP TEMPERATURE SETTING BEEP RATE SETTING

#### CHANGE TO STAGE 4

BEEP TEMPERATURE SETTING BEEP RATE/TIME SETTING

#### CHANGE TO STAGE 5

BEEP TEMPERATURE SETTING BEEP RATE SETTING

#### CHANGE TO STAGE 6

BEEP TEMPERATURE SETTING BEEP TIME SETTING

THE CONTROLLER WILL NOW START.

#### WHEN CONTROLLER IS RUNNING

You may check the settings of the stage you are on simply by pushing the required button. The stage lights will blink until button released. The controller is not interrupted.

You may CHECK or CHANGE all settings with the controller running by pushing and releasing CYCLE and going to **SETTING UP THE SELECTED PROGRAM.**

The controller is not interrupted.

If the controller is in a SOAK STAGE pressing and holding the RATE/TIME button will give you the TIME SET and then the reading will change to give you TIME GONE since entering the SOAK stage.

**APPROXIMATE COMPARISONS FOR STARTING POINT.  
HARCO NUMBERS TO CONES**

As there is no reference that I can use except temperatures for my table I have set up below an approximation to cone numbers.

This may be used as a starting point for trial runs to arrive at the correct number to use in your application.

HARCO NUMBER	CONE NUMBER	HARCO NUMBER	CONE NUMBER
30	022	66	04
32	021	68	03
34	020	70	02
36	019	72	01
38	018	74	1
40	017	76	2
42	016	78	3
44	015	80	4
46	014	82	5
48	013	84	6
50	012	86	7
52	011	88	8
54	010	90	9
56	09	92	10
58	08	94	11
60	07	96	12
62	06	98	13
64	05	100	14

**IMPORTANT**

DO NOT ASSUME THAT THIS TABLE IS A DIRECT EQUIVALENT TO CONES.

**USING THE HARCO NUMBERS**

If you SET a HARCO NUMBER

Look up the approximate cone number in the HARCO tables and refer to the CONE TEMPERATURE in the cone suppliers table closest to the rate you are using.

ENTER a SOAK in your LAST STAGE at this temperature to be longer than the cut off by the HARCO number.

YOU MAY HAVE TO TRY A FEW TIMES TO GET IT RIGHT.

- (1) If the controller is CUT OFF by the HARCO number the CONE light will be BLINKING and the CYCLE OVER light will be ON.
- (2) If the controller is CUT OFF by the PROGRAM ENDING the CYCLE OVER light ONLY will be ON.

In case (2) LENGTHEN YOUR SOAK TIME.

**THERMOCOUPLE**

THE CONTROLLER IS MARKED AS BELOW:

<b>K</b>	Use only	CHROMEL/ALUMEL	TYPE K
<b>R</b>	Use only	PLATINUM/RHODIUM	TYPE R
<b>N</b>	Use only	NISIL/NICROSIL	TYPE N

The RED connector in the compensation lead is NEGATIVE.

Check connection by HEATING the end of the THERMOCOUPLE.

If READING DECREASES reverse the connections.

**EXAMPLES ONLY** *These are not programs to be used*

1. (a) You require the kiln to climb to a temperature of 600 deg.C at a rate of 100 deg. per hour.  
(b) Then climb to 1100 deg.C at a rate of 300 deg. per hour.  
(c) TURN OFF.

**Procedure:**

Stage 1	Temperature	600	Rate	100
Stage 2	Already set to	600	Time	000
Stage 3	Temperature	1100	Rate	300
Stage 4	Already set to	1100	Time	000
Stage 5	Temperature	000	Rate	000
Stage 6	Temperature	000	Time	000

2. (a) You require the kiln to climb to a temperature of 1000 deg.C at a rate of 120 deg. per hr.  
(b) Soak or Hold for 15 minutes.  
(c) TURN OFF.

**Procedure:**

Stage 1	Temperature	1000	Rate	120
Stage 2	Already set to	1000	Time	015
Stage 3	Temperature	000	Rate	000
Stage 4	Already set to	000	Time	000
Stage 5	Temperature	000	Rate	000
Stage 6	Temperature	000	Time	000

3. (a) You require the kiln to go to a temperature of 600 deg.C at a rate of 90 deg. per hour.  
(b) Then to a temperature of 1000 deg.C at a rate of 120 deg.C per hour.  
(c) Then climb to 1180 deg.C. at a rate of 150 deg. per hour.  
(d) Soak or Hold for 30 minutes.  
(e) Then drop to 500 deg.C. at a rate of 50 deg. per hour.  
(f) Soak or hold for 15 minutes.

**Procedure:**

Stage 1	Temperature	600	Rate	090
Stage 2	Temperature	1000	Rate	120
Stage 3	Temperature	1180	Rate	150
Stage 4	Already set to	1180	Time	030
Stage 5	Temperature	500	Rate	050
Stage 6	Temperature	500	Time	015

### POWER FAILURE

*On return of power the controller will:*

- (1) Remain in the reset state if off for more than approx. 5 minutes.
- (2) Power to the kiln will be off. (To protect kiln from possible BURNOUT).  
*Otherwise the cycle will resume.*

### UP or DOWN

When pushing the UP or DOWN pushbutton, the reading changes slowly at first but increases its speed the longer the button is held. When the change is 100 counts from the original reading it will increment in 100s to allow fast changes. When you are close to the setting required release the pushbutton and press it again to slow down the rate of change.

## SAFETY CHECKS

During normal operation the controller checks:

- (1) for thermocouple failure.
- (2) that thermocouple is in the kiln or furnace.
- (3) for shorts in thermocouple compensation lead.  
(checks (2) & (3) done over a time depending on rate set.
- (4) checks for kiln reaching temperature.
- (5) for relay circuit failure. (which could cause BURNOUT)

STEPS (1), (2), (3) & (4) SOUND ALARM AND SHUT POWER OFF KILN.

STEP (5) SOUNDS ALARM BUT IS UNABLE TO SHUT POWER OFF KILN.

MAY RESULT IN BURNOUT - ALWAYS ATTEND KILN.

## DIRECT WIRING THE CONTROLLER

*(Using the kiln or furnace relay)*

- (1) Mount "CLIPSAL" 410 socket on kiln or furnace.
- (2) Connect ACTIVE (A2), NEUTRAL (N) & EARTH (E) to socket. (mains supply for controller)
- (3) Disconnect controlled active line which goes to the kiln or furnace contactor coil. (COIL MUST BE 240 VAC)  
(Usually has a door switch and simmerstat in series with contactor coil. Disconnect on active side of these.)
- (4) Connect wire to (A1) (controlled active) on the socket.  
THE CONTROLLER SHOULD BE READY TO BE PLUGGED IN.  
The simmerstat must be set to MAXIMUM.  
THE CONTROLLED ACTIVE FROM CONTROLLER IS RATED AT 240 VOLTS A.C. at 5 AMPS MAXIMUM.

## MOST COMMON PROBLEMS

- (1) ALARM SOUNDS WITHIN MINUTES. (of starting)  
CHECK that CONTROL LIGHT is coming ON.  
**IF YES:**
  - (a) CHECK that DOOR SWITCH is operating.
  - (b) LISTEN for KILN CONTACTOR closing.
  - (c) CHECK THERMOCOUPLE and CONNECTIONS to it.
- (2) NOT COMPLETING CYCLE. (not reaching SET TEMPERATURE.)  
CHECK that CONTROL LIGHT IS ON.  
**IF YES:**
  - (a) Possible HEATING ELEMENT FAILURE.
  - (b) DOOR SWITCH opening with heat.
- (3) DISPLAY READING OVER 1400°C  
CHECK that lights on controller are ON.  
**IF YES:**
  - (a) CHECK THERMOCOUPLE for open circuit.
  - (b) CHECK for bad connections to THERMOCOUPLE OR CONTROLLER.**IF DISPLAY BLANK AND NO LIGHTS:**  
CHECK POWER TO CONTROLLER.

## WARRANTY

(Applicable only to products marketed and used within the Commonwealth of Australia.) During the first period of ownership, ie. 6 months from the date of purchase as the original purchaser of the equipment, Harco Electronics guarantees that any part which we find defective on materials or workmanship will be repaired or replaced free of charge for the parts and service labour, provided that all service is performed by Harco Electronics or by an Authorised agent. If service is required at place of installation charges will apply or the controller returned to Harco Electronics or Authorised agent **AT COST TO PURCHASER**. N.B. This protection is yours for HOUSEHOLD USE only. Commercial usage would restrict the warranty to ninety days from the date of purchase. Six months may apply to commercial usage if written approval is given by Harco Electronics. The warranty does not cover failure due to accidental damage, misuse, negligence, consequential damage, modification, or where the controller is not installed and operated in accordance with any statutory regulations, the appropriate installation code, or with details appearing on the controller rating plate. The warranty is valid wherever you live in Australia even if you move. For ready recognition of your warranty, record the date of purchase hereon and retain this for your record. Also retain proof of purchase as you may be asked to produce same in event of a service claim. This warranty is the sole guarantee by the manufacturers and they are not responsible for any other obligations assumed or expressed by any other person or persons. No other remedy shall be available to the buyer (except the conditions contained in this warranty) for damage to kilns, ware or property, lost profits, or lost sales or any other consequential or accidental loss.

PURCHASER:.....

ADDRESS:.....

POSTCODE:..... TELEPHONE NUMBER:.....

EQUIPMENT:..... DATE OF PURCHASE:.....

SERIAL No. .... RETAILER:.....

Please look after your warranty. It is reassuring to know that you have its protection, even though you may never need it.

## KILN WIRING (ELECTRIC)

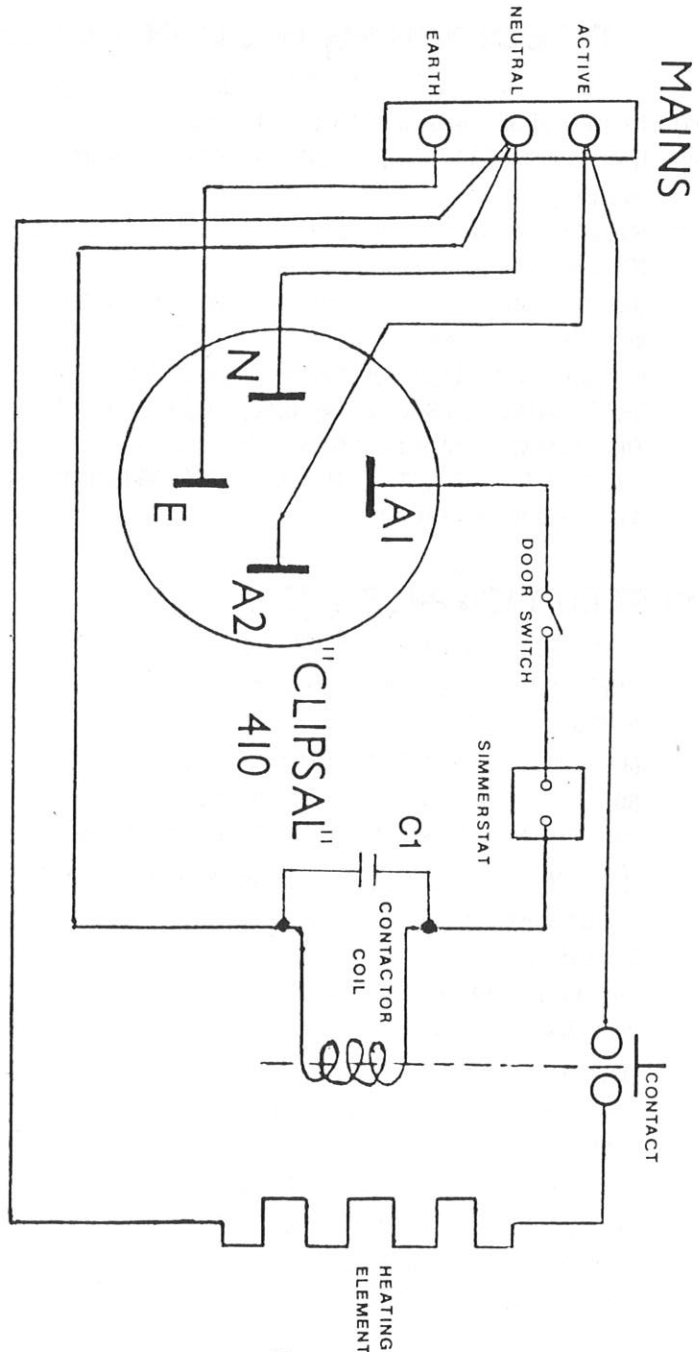

NOTE  
If simmerstat included it must  
be switched to FULL ON.

C1 = 0.1 Mfd. 250 Vac  
Mainscap.